

512

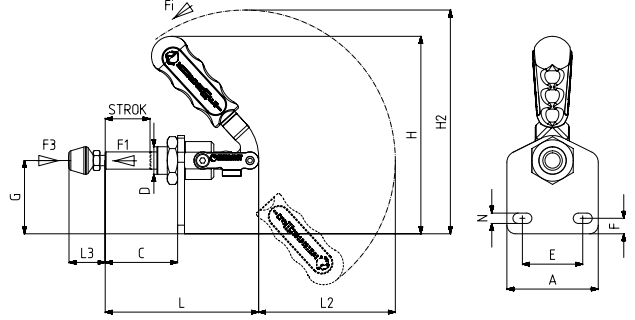

MODEL NO	PASLANMAZ (STAINLESS)	SİYAH (BLACK)	F1 (N)	F3 (N)	Fi VERİM (YIELD) (F1:Fi)	BASKI VİDASI (SQUEEZE SCREW)	STROK	AĞIRLIK (WEIGHT) (gr)
512-2	S 512 -	B 512 -	1500	1700	26:1	M6X40	27	280
512-3	S 512 -	B 512 -	2500	2640	27:1	M8X50	38	490
512-5	S 512 -	B 512 -	3500	3700	38:1	M10X70	53	960
512-6	S 512 -	B 512 -	4500	4650	38:1	M10X70	53	1070

F1 : BASKI KUVVETİ (EXERTING FORCE) , F3 : TUTMA KAPASİTESİ (HOLDING CAPACITY) , Fi : UYGULAMA KUVVETİ (APPLIED FORCE)



Ayak Tipi: Dikey Tabanlı
Body Mounting Base: Vertical

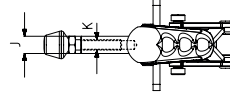

MODEL NO	A	B	C	D	E	F	G	H	H2	J	K	L	L2	L3 Min	L3 Max	M	N
512-1	44		34	M12 x 1,5	21,5 - 31,5	8,5	35	95	108	8	M5	73	68,5	15	38		5,5 x 10,5
512-2	53		42	M16 x 1,5	30 - 40	9	42,5	114	129	10	M6	89	80	19	46		6 x 11
512-3	60		56	M20 x 1,5	33,5 - 42,5	12,5	52	158	161	12	M 8	116	80	24	58		6,5 x 11
512-5	78		75	M24 x 1,5	42 - 57	15	64,5	178	206	14	M10	155	135	32	74		8,5 x 16
512-6	78		75	M24 x 1,5	42 - 57	15	64,5	178	206	16	M10	155	135	32	74		8,5 x 16

513



MODEL NO	PASLANMAZ (STAINLESS)	SİYAH (BLACK)	F1 (N)	F3 (N)	Fi VERİM (YIELD) (F1:Fi)	BASKI VİDASI (SQUEEZE SCREW)	STROK	AĞIRLIK (WEIGHT) (gr)
513-2	S 513 -	B 513 -	1500	1700	26:1	M6X40	27	200
513-3	S 513 -	B 513 -	2500	2640	27:1	M8X50	38	360
513-5	S 513 -	B 513 -	3500	3700	38:1	M10X70	53	710
513-6	S 513 -	B 513 -	4500	4650	38:1	M10X70	53	780

F1 : BASKI KUVVETİ (EXERTING FORCE) , F3 : TUTMA KAPASİTESİ (HOLDING CAPACITY) , Fi : UYGULAMA KUVVETİ (APPLIED FORCE)

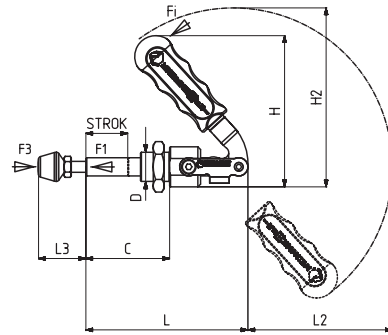

Ayak Tipi: Tabansız
Body Mounting Base: No Base

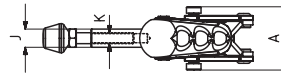

MODEL NO	A	B	C	D	F	G	H	H2	J	K	L	L2	L3 Min	L3 Max	M	N
513-1	28		37	M12 x 1,5			69	82	8	M5	73	68,5	15	38		
513-2	32		46	M16 x 1,5			81,5	97	10	M6	89	80	19	46		
513-3	39		61	M20 x 1,5			100	103	12	M 8	116	80	24	58		
513-5	47		81	M24 x 1,5			131	159	14	M10	155	135	32	74		
513-6	51		81	M24 x 1,5			131	159	16	M10	155	135	32	74		